

Effects of External Power Amplifier Impedance on Measurements

Auxiliary RF and Microwave power amplifiers are often used in conjunction with other test equipment to help evaluate aspects of performance of a particular component or system. The supporting amplifier is often considered an “ideal” amplifier during the initial configuration of the test and measurement system. This assumption can result in significant errors that end up with the user acquiring additional, higher power amplifiers to perform the necessary tests, adding the critical elements of time and cost to the process.

Higher power than that generally available from a commercial signal generator is often needed for lab or range test purposes. A few component examples include test of limiters, mixers, high power amplification stages, device burn out threshold determination. System examples include EMC/EMI test, radar cross section evaluation, stealth material and structure performance, ECCM immunity, and jammer simulation. Power requirements vary from 1/10 watt (20 dBm) to several hundreds or thousands of watts, depending on the application. Figure 1 illustrates what might be a simple generic test situation with an auxiliary power amplifier. More complex configurations may include antennas, receivers, spectrum analyzers, as well as multiple signal sources and auxiliary amplifiers.

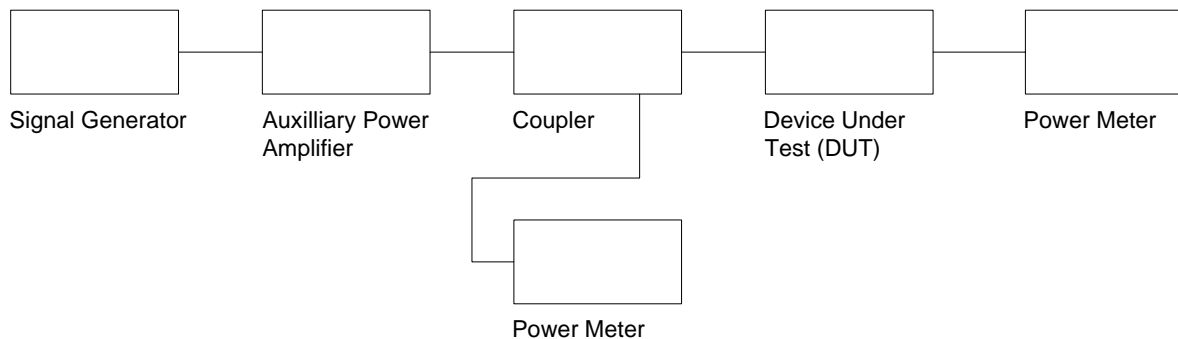

Figure 1

A common assumption made by less experienced personnel is the amplifier has little effect on the test other than to boost the signal power to the desired level. Ideally, this is true, but in most instances, the amplifier has the capability to introduce significant implications to the test. Depending on the test, these may include additional noise power, intermodulation, or non linear signal amplification, test signal

ripple, and others. Each issue must be considered and accommodated by the test designer. This application note addresses the potential implications of the amplifier VSWR upon the test configuration.

Microwave and RF power amplifiers often have notoriously poor VSWRs, both input and output, when compared with other microwave test equipment. This is exacerbated when very broadband (octave and higher) amplifiers, or non linear (Class AB, B, C, etc) or TWTA (traveling wave tube amplifiers) are used. A survey of one popular amplifier supplier shows several amplifiers specified with 2.5:1 maximum input VSWR, and 2.5:1 typical output VSWR.

Unfortunately, many of the devices that require the use of an auxiliary power amplifier to test, such as broadband antennas, power amplification stages or power semiconductor devices, or limiters, also exhibit poor VSWRs. Combining the load impedance with cabling and a potentially poor output impedance from an amplifier can result in substantial amplitude ripple in the response of the system, and markedly less power delivered to the load than anticipated.

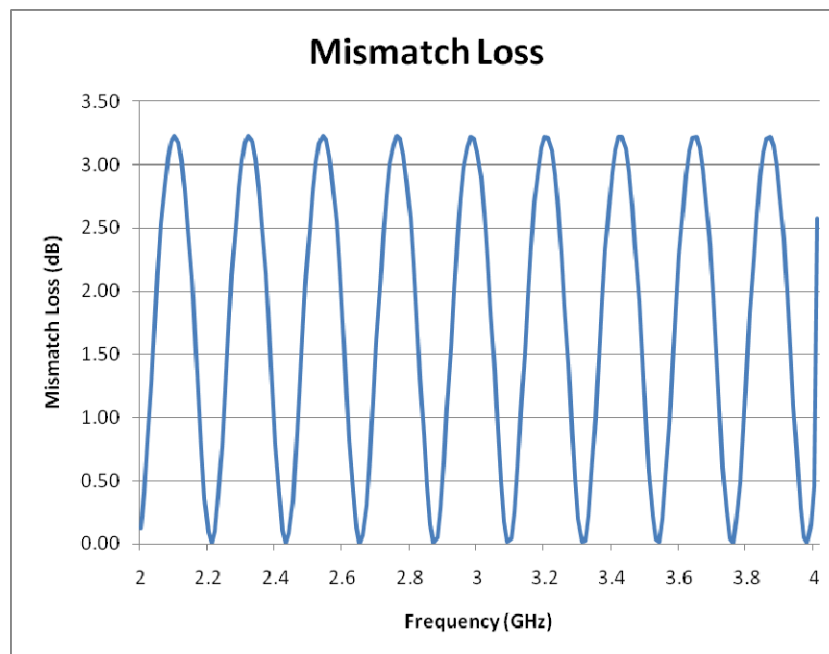

Figure 2

Figure 2 illustrates the amplitude ripple due to mismatch of a hypothetical power amplifier with an output impedance of $20 + j0$ ohms (2.5:1 VSWR) separated from a hypothetical load impedance of $20 + j0$

ohms by a 0.48 meter coaxial cable. Only the response from 2 to 4 GHz is shown for clarity. As evidenced by the chart, one would expect that at certain frequencies, less than 50% (corresponding to >3 dB) of the power actually impinges upon the load.

Monitoring and Compensation

Since real world VSWRs of practical devices always exceed 1:1, efforts must be made to:

- 1) Know how much power reaches the load and,
- 2) Maximize the available power to the load.

In general, the use of a calibrated high directivity (>20 dB) coupler with a power meter, as shown in Figure 1, can adequately monitor the incident power at the load at the expense of additional insertion loss due to the coupling. For practical applications, this will be less than 0.5 dB additional loss due to resistive and coupling losses of a 30-40 dB coupler. Also, with a single coupler measurement, some power measurement error will remain due to the coupler directivity.

Monitoring the power at least resolves the issue of how much power is incident upon the DUT, but it does not, by itself increase the available power at the DUT. For the example listed above, the power loss at 3 GHz exceeds three dB. If the amplifier is running below its rated power level, the user may increase the drive level into the power level until the measured output power level reaches the desired level. If there is insufficient power available from the amplifier, one needs to take use other methods.

The simplest (and most expensive) method is to acquire and use a power amplifier with more output power capacity. This may not be feasible due to time, budget, equipment availability, or any number of other reasons.

Alternatively, one can adjust the cable length to maximize the amount of available power to the load at the specific frequency of measurement. Figure 3 shows the variation in mismatch loss for the amplifier

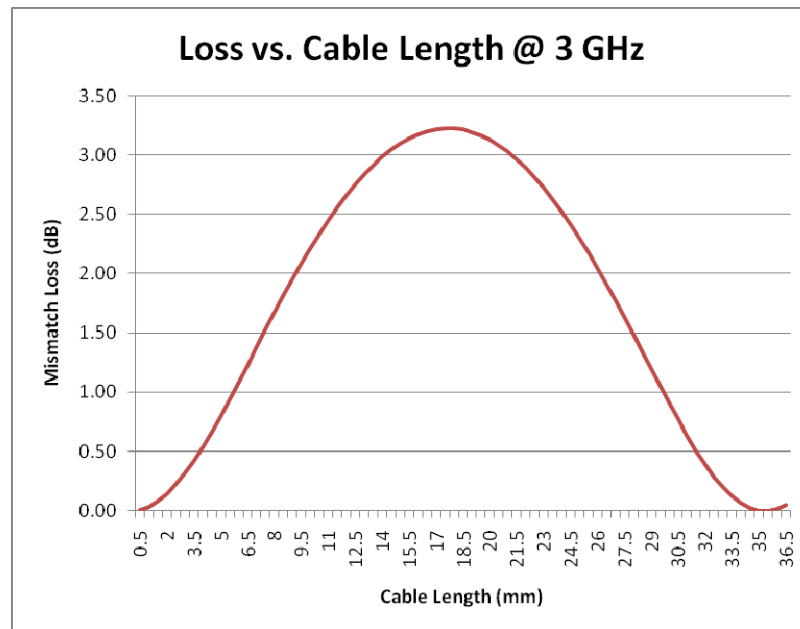

Figure 3

and DUT impedance of $20 + j0$ ohms in the example above as the cable length is varied from 0 to 36.5 mm. One can see quite clearly that over 3 dB, or 50% of the power will be unavailable at the load due to reflection for a cable length of ~18 mm.

While this technique will allow the user to optimize the test configuration to allow maximum power incident upon the DUT, it must be applied one frequency at a time, and reoptimized at every frequency, a time consuming and tedious chore if an automated tuning or load pull system is not employed.

A third method that can be implemented, at least for moderate band width measurements, is incorporation of an isolator at the output of the auxiliary amplifier to isolate the amplifier mismatch from the 50 ohm cable. This will reduce the standing wave, but still results in less than full power being available to the load. The power is reduced by any insertion loss of the isolator, and still reduced by the mismatch loss presented by the load.

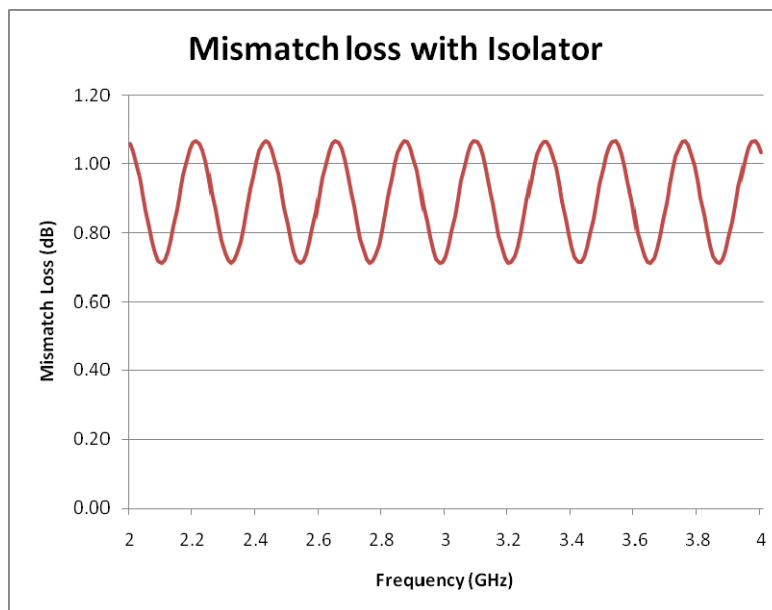

Figure 4

Figure 4 illustrates the effective mismatch loss of an amplifier with a $20 +j0$ ohm output impedance followed by a hypothetical broadband isolator with a 1.1:1 VSWR, a 0.48 meter cable, and a DUT with a $20+j0$ ohm input impedance. This figure does not include any isolator or cable loss. It also does not include ripple or loss due to the amplifier to isolator junction, assumed to be minimal due to a very short connection electrical length between the two. The power available to the load is still ~ 1 dB less than the output power of the amplifier. Additional losses will be incurred due to the insertion loss of the isolator, perhaps as high as 0.5-1 dB additional insertion loss, since the isolator must also handle high power levels. One must ensure that the isolator itself does not exceed its Curie temperature due to self heating and thus become an unknown three port network, with high insertion loss and poor return loss.

The best option for ensuring that sufficient power is available to the DUT is to use an amplifier with adequate power margin and good output return loss, in conjunction with using low loss cable, low loss

CAP Notes

directional coupling for power monitoring, and other good measurement techniques and practices. CAP Wireless broad band test equipment power amplifiers using Spatium™ amplifiers with CAPLine™ technology provide the broadest continuous frequency coverage in the industry. They provide moderate to high levels of output power with good output VSWR, facilitating applications where substantial power must be delivered to an antenna or test device.